

For Precast
& Tilt-up
Construction

CHAMFERS

1/2 Inch x 60 Low Profile

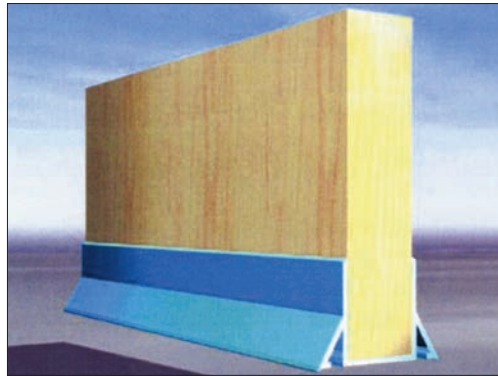

Installation

- **Step 1** – Fasten the chamfers in place using fastener, tape or Adhesive.
- **Step 2** – Check to ensure that the chamfer's edge is pressed firmly against the casting surface.
- **Step 3** – Insert lumber along the length. For wood that is swollen beyond standard dimensions, insert one side first against the flex edge then roll the other side into the channel.
- **Step 4** – For single Chamfer, align chamfer along the form and casting surface. Press firmly against both and staple or nail into place. Nail guns are NOT recommended.

(No form coat or bond breaker needed)

Coefficient of Linear Expansion:
.0132 inches per degree F

Storage: Materials should be stored out of direct sunlight to prevent long-term deterioration or color fading. Pieces can be stacked, but should be stored fully supported to keep them from warping.

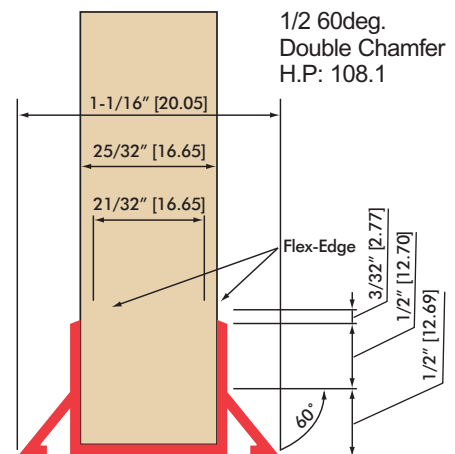
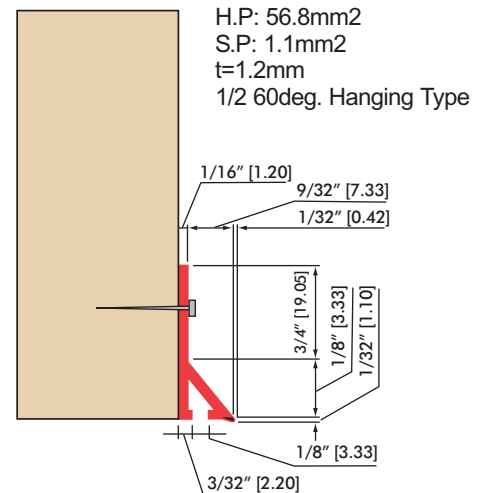

Fukuvi USA, Inc.
Victory Bear Products
7631 Progress Court
CenterPoint 70 Commerce Park
Huber Heights, OH 45424

www.fukuvi-usa.com
www.victorybear.com

Customer Support
Jon Dresel
(937) 236-7288 ext. 231
jdresel@fukuvi-usa.com
Fax: (937) 236-7289

