

For Precast  
& Tilt-up  
Construction



## **BULKHEAD** (3/4" x 45°)

Victory Bear is an innovative concrete product supplier with deep roots in the tilt-up, pre-cast, and cast-in-place industries. We offer the most complete line of tilt-up profiles in the industry. Our base clip design makes our rustications and bulkheads **reusable**.

Our rustications and chamfers produce the cleanest and sharpest finishes in the industry. Victory Bear is a leader in innovative exterior concrete designs – creating products, for now and for the future, that will provide the tilt-up and pre-cast industry with unique options. Our products provide flexibility to designers, allowing for a variety of design configurations in a variety of building types.

### Features & Benefits

- **100% PVC Reduces Costs** – PVC virtually eliminates concrete pitting caused by wood-wicking. It also eliminates discoloration caused by wood sugars. It almost entirely **eliminates the need for grinding and patching**, saving you man-hours or subcontractor expenses.
- **Patented “Flexible Edge Seal”** – Our patented Flexible Edge Seal fits tightly against the casting surface, preventing concrete seepage while creating **sharp, crisp lines**.
- **Hidden Fastening System** – No finish blemishes from screw heads or excess glue. With Victory Bear Bulkhead all screws and glue remnants are hidden under the surface for a sharp, **glass-like finish**.
- **Reduces Your Forming Cost** – Victory Bear Bulkhead has been redesigned for use with both 3/4 - inch plywood and 1 - inch lumber, allowing you a choice of form boards.

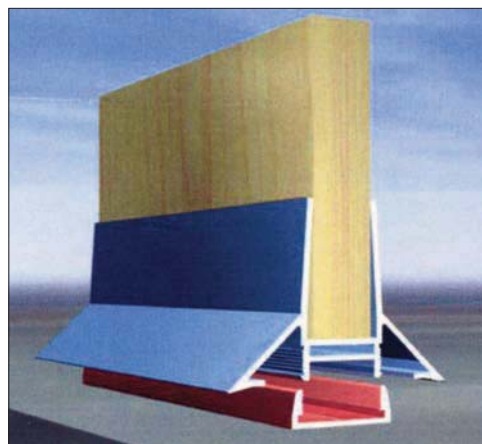

**Fukuvi USA, Inc.**  
**Victory Bear Products**  
7631 Progress Court  
CenterPoint 70 Commerce Park  
Huber Heights, OH 45424

[www.fukuvi-usa.com](http://www.fukuvi-usa.com)  
[www.victorybear.com](http://www.victorybear.com)



**MADE IN USA**

**Customer Support**  
(937) 236-7288 ext. 247/231  
[aheskett@fukuvi-usa.com](mailto:aheskett@fukuvi-usa.com)  
[jdresel@fukuvi-usa.com](mailto:jdresel@fukuvi-usa.com)  
Fax: (937) 236-7289

For Precast  
& Tilt-up  
Construction



## BULKHEAD (3/4" x 45°)

### Installation

- **Step 1** – Fasten the Base Clip to the casting surface with fasteners, tape, or adhesive.
- **Step 2** – Press one end of the Bulkhead's interlocking tooth grip into the end of the Base Clip.
- **Step 3** – Press the entire length of the Bulkhead into the Base Clip.
- **Step 4** – Check to ensure that the interlocking grips are fully engaged and the chamfer seal is pressed firmly against the casting surface.
- **Step 5** – Using a 1" board, apply downward pressure in the channel of the Bulkhead, working from one end to the other until it locks into position. This creates a tight friction fit with the wood, preventing it from rising during the pour. No nailing is necessary.

Bulkhead 1 x 3/4" Double Chamfer

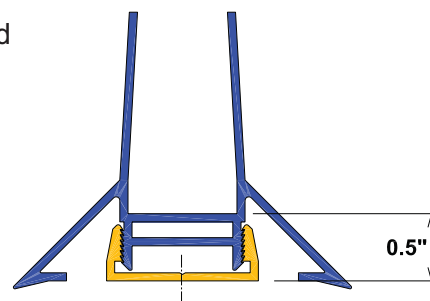
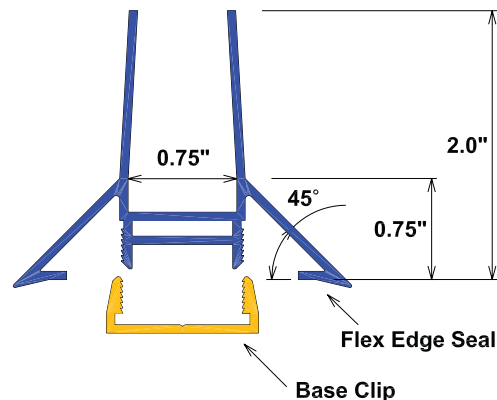

**Length:** 8 feet

### Coefficient of Linear Expansion:

.0132 inches per degree F

**Storage:** Materials should be stored on a flat surface out of direct sunlight. Pieces can be stacked, but should be stored fully supported to keep them from warping.

Fukuvi USA, Inc.  
Victory Bear Products  
7631 Progress Court  
CenterPoint 70 Commerce Park  
Huber Heights, OH 45424

www.fukuvi-usa.com  
www.victorybear.com



**MADE IN USA**

**Customer Support**  
(937) 236-7288 ext. 247/231  
aheskett@fukuvi-usa.com  
jдресel@fukuvi-usa.com  
Fax: (937) 236-7289